

**Q. No. 1 – 25 Carry One Mark Each**

1. The infinite series  $f(x) = \frac{x^3}{3!} + \frac{x^5}{5!} + \frac{x^7}{7!} + \dots + \dots + \dots + \infty$  converges to  
 (A)  $\cos(x)$   
 (B)  $\sin(x)$   
 (C)  $\sinh(x)$   
 (D)  $e^x$
2. The diameters of 10000 ball bearings were measured. The mean diameter and standard deviation were found to be 10mm and 0.05mm respectively. Assuming Gaussian distribution of measurements, it can be expected that the number of measurements more than 10.15mm will be  
 (A) 230  
 (B) 115  
 (C) 15  
 (D) 2
3. A person weighing 60 kg receives radiation energy of 0.3J over the entire body. The dose of radiation absorbed (in rad) is  
 (A) 0.005 rad  
 (B) 0.1 rad  
 (C) 0.3 rad  
 (D) 0.5 rad
4.  $u(t)$  represents the unit step function. The Laplace transform of  $u(t-\tau)$  is  
 (A)  $\frac{1}{s\tau}$   
 (B)  $\frac{1}{s-\tau}$   
 (C)  $\frac{e^{-s\tau}}{s}$   
 (D)  $e^{-s\tau}$
5. A measurement system with input  $x(t)$  and output  $y(t)$  is described by the differential equation  $3 \frac{dy}{dt} + 5y = 8x$ . The static sensitivity of the system is  
 (A) 0.60  
 (B) 1.60  
 (C) 1.67  
 (D) 2.67
6. Poisson's ratio for a metal is 0.35. Neglecting piezo-resistance effect, the gage factor of a strain gage made of this metal is  
 (A) 0.65  
 (B) 1  
 (C) 1.35  
 (D) 1.70
7. Match the Following

P. Radiation Pyrometer	W. Angular velocity measurement
Q. Dall tube	X. Vacuum pressure measurement
R. Pirani gauge	Y. Flow measurement
S. Gyroscope	Z. Temperature measurement

- (A) P-Z, Q-W, R-X, S-Y  
 (B) P-Z, Q-Y, R-X, S-W

- (C) P-W, Q-X, R-Y, S-Z  
 (D) P-Z, Q-X, R-W, S-Y

8. In a pulse code modulated (PCM) signal sampled at  $f_s$  and encoded into an  $n$ -bit code, the minimum bandwidth required for faithful reconstruction is  
 (A)  $2nf_s$  (C)  $nf_s/2$   
 (B)  $nf_s$  (D)  $f_s$
9. A beam of unpolarized light is first passed through a linear polarizer and then through a quarter-wave plate. The emergent beam is  
 (A) unpolarized (C) circularly polarized  
 (B) linearly polarized (D) elliptically polarized
10.  $f(x)$ , shown in the adjoining figure is represented by  $f(x) = a_0 + \sum_{n=1}^{\infty} \{a_n \cos(nx) + b_n \sin(nx)\}$ . The value of  $a_0$  is

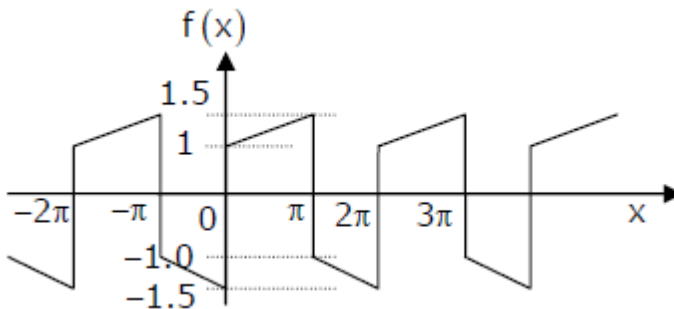

- (A) 0  
 (B)  $\frac{\pi}{2}$   
 (C)  $\pi$   
 (D)  $2\pi$
11. The PMMC ammeter A in the adjoining figure has a range of 0 to 3mA. When switch S1 is opened, the pointer of the ammeter swings to the 1mA mark, returns and settles at 0.9mA. The meter is

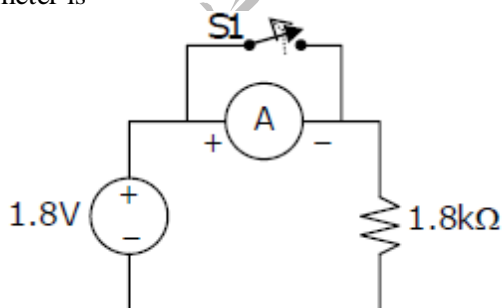

- (A) critically damped and has a coil resistance of  $100\Omega$   
 (B) critically damped and has a coil resistance of  $200\Omega$   
 (C) under damped and has a coil resistance of  $100\Omega$   
 (D) under damped and has a coil resistance of  $200\Omega$

12. The open loop transfer function of a unity gain feedback system is given by:

$$G(s) = \frac{k(s+3)}{(s+1)(s+2)}$$

The range of positive values of  $k$  for which the closed loop system will remain stable is:

- (A)  $1 < k < 3$  (C)  $5 < k < \infty$   
 (B)  $0 < k < 10$  (D)  $0 < k < \infty$

13. A real  $n \times n$  matrix  $A = [a_{ij}]$  is defined as follows:  $a_{ij} = i$ , if  $i = j = 0$ , otherwise The summation of all  $n$  eigen values of  $A$  is

- (A)  $n(n+1)/2$  (C)  $\frac{n(n+1)(2n+1)}{6}$   
 (B)  $n(n-1)/2$  (D)  $n^2$

14. The contour  $C$  in the adjoining figure is described by  $x^2 + y^2 = 16$ . The value of  $\oint_C \frac{z^2+8}{0.5z-1.5j} dz$  is.

(Note:  $j = \sqrt{-1}$ )

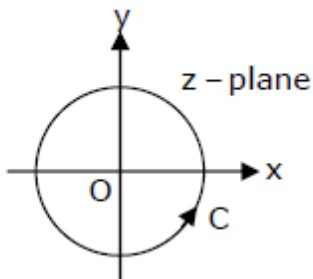

- (A)  $-2\pi j$  (C)  $4\pi j$   
 (B)  $2\pi j$  (D)  $-4\pi j$

15. In the dc circuit shown in the adjoining figure, the node voltage  $V_2$  at steady state is

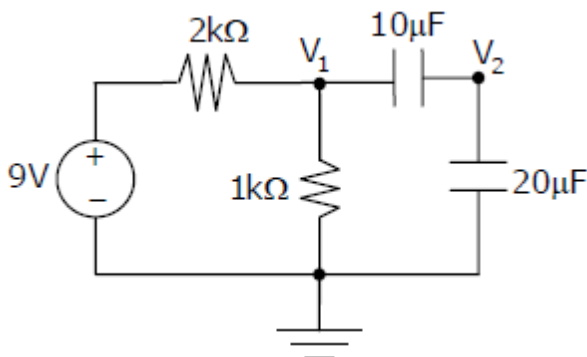

- (A) 0V (C) 2V  
 (B) 1V (D) 3V

16. A  $100\ \Omega$ , 1W resistor and a  $800\ \Omega$ , 2W resistor are connected in series. The maximum dc voltage that can be applied continuously to the series circuit without exceeding the power limit of any of the resistors is
- (A) 90V (C) 45 V  
(B) 50 V (D) 40V
17. The seismic mass of an accelerometer oscillates sinusoidally at 100Hz with a maximum displacement of 10mm from its mean position. The peak acceleration of the seismic mass is
- (A)  $3947.84\text{m/s}^2$  (C)  $314.15\text{m/s}^2$   
(B)  $3141.50\text{m/s}^2$  (D)  $100.00\text{m/s}^2$
18. In the ideal opamp circuit given in the adjoining figure, the value of  $R_f$  is varied from  $1\text{k}\ \Omega$  to  $100\text{k}\ \Omega$ . The gain  $G = \left(\frac{V_o}{V_i}\right)$  will

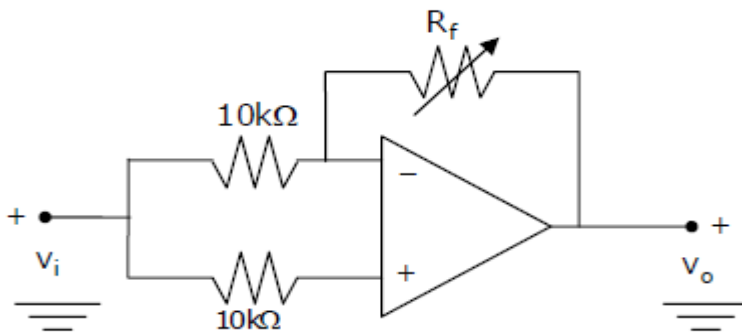

- (A) remain constant at +1  
(B) remain constant at -1  
(C) vary as  $-(R_f/10,000)$   
(D) vary as  $(1 + R_f/10,000)$
19. A signal with frequency components 50Hz, 100Hz and 200Hz only is sampled at 150samples/s. The ideally reconstructed signal will have frequency component(s) of
- (A) 50Hz only (C) 50Hz and 75Hz  
(B) 75Hz only (D) 50Hz, 75Hz and 100Hz
20. The subroutine SBX given below is executed by an 8085 processor. The value in the accumulator immediately after the execution of the subroutine will be:
- ```

SBX : MVI A, 99h
      ADI 11h
      MOV C,A
      RET

```
- (A) 00h (C) 99h  
(B) 11h (D) AAh

21. The integral  $\int_{-\infty}^{\infty} \delta\left(t - \frac{\pi}{6}\right) 6\sin(t)dt$  evaluates to  
 (A) 6 (C) 1.5  
 (B) 3 (D) 0
22. The deflection angle of the pointer of an ideal moving iron ammeter is  $20^\circ$  for 1.0 ampere dc current. If a current of  $3\sin(314t)$  amperes is passed through the ammeter then the deflection angle is  
 (A)  $0^\circ$  (C)  $60^\circ$   
 (B)  $42^\circ$  (D)  $90^\circ$
23. A 8-bit DAC is interfaced with a microprocessor having 16 address lines ( $A_0 \dots A_{15}$ ) as shown in the adjoining figure. A possible valid address for this DAC is

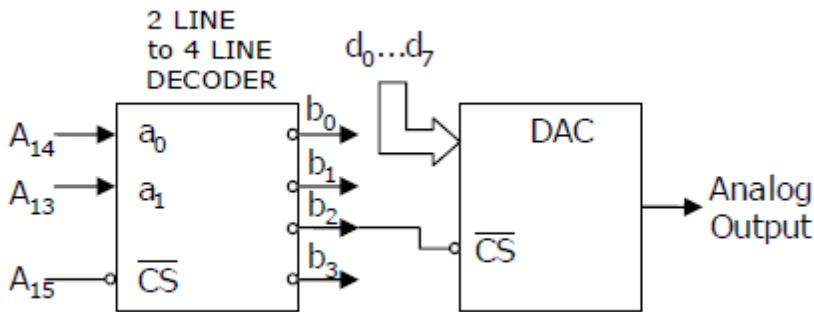

- (A) 3000h (C) AFFFh  
 (B) 4FFFh (D) C000h
24.  $H(z)$  is a discrete rational transfer function. To ensure that both  $H(z)$  and its inverse are stable its  
 (A) poles must be inside the unit circle and zeros must be outside the unit circle  
 (B) poles and zeros must be inside the unit circle  
 (C) poles and zeros must be outside the unit circle  
 (D) poles must be outside the unit circle and zeros should be inside the unit circle
25. The output voltage of a transducer with an output resistance of  $10k\Omega$  is connected to an amplifier. The minimum input resistance of the amplifier so that the error in recording the transducer output does not exceed 2% is  
 (A)  $10k\Omega$  (C)  $490k\Omega$   
 (B)  $49k\Omega$  (D)  $1.2M\Omega$

**Q. No. 26 – 55 Carry Two Marks Each**

26. X and Y are non-zero square matrices of size  $n \times n$ . If  $XY=0_{n \times n}$  then  
(A)  $|X| = 0$  and  $|Y| \neq 0$  (C)  $|X| = 0$  and  $|Y| = 0$   
(B)  $|X| \neq 0$  and  $|Y| = 0$  (D)  $|X| \neq 0$  and  $|Y| \neq 0$
27. Consider the differential equation  $\frac{dy}{dx} + y = e^x$  with  $y(0)=1$ . The value of  $y(1)$  is  
(A)  $e + e^{-1}$  (C)  $\frac{1}{2}(e + e^{-1})$   
(B)  $\frac{1}{2}(e - e^{-1})$  (D)  $2(e - e^{-1})$
28. The electric charge density in the region  $R : x^2 + y^2 \leq 1, y \leq 0$  is given as  $\sigma(x, y) = 1C/m^2$ , where  $x$  and  $y$  are in meters. The total charge (in coulomb) contained in the region  $R$  is  
(A)  $4\pi$  (C)  $\frac{\pi}{2}$   
(B)  $2\pi$  (D)  $0$
29. The input  $x(t)$  and the corresponding output  $y(t)$  of a system are related by  $y(t) = \int_{-\infty}^{5t} x(\tau) d\tau$ . The system is  
(A) time invariant and causal (C) time variant and noncausal  
(B) time invariant and noncausal (D) time variant and causal
30. A digital filter having a transfer function  $H(z) = \frac{p_0 + p_1 z^{-1} + p_3 z^{-3}}{1 + d_3 z^{-3}}$  is implemented using Direct Form – I and Direct Form – II realizations of IIR structure. The number of delay units required in Direct Form – I and Direct Form – II realizations are, respectively  
(A) 6 and 6 (C) 3 and 3  
(B) 6 and 3 (D) 3 and 2
31. The velocity  $v$  (in m/s) of a moving mass, starting from rest, is given as  $\frac{dv}{dt} = v + t$ . Using Euler forward difference method (also known as Cauchy-Euler method) with a step size of 0.1s, the velocity at 0.2s evaluates to  
(A) 0.01 m/s (C) 0.2 m/s  
(B) 0.1m/s (D) 1 m/s
32. The rotor of the control transformer of a synchro pair gives a maximum voltage of 1.0V at a particular position of the rotor of the control transmitter. The transmitter is now rotated by  $30^\circ$  anticlockwise keeping the transformer rotor stationary. The transformer rotor voltage for this position is  
(A) 1.0V (C) 0.5V  
(B) 0.866V (D) 0V

33. The matched transistors Q1 and Q2 shown in the adjoining figure have  $\beta = 100$ . Assuming the base-emitter voltages to be  $0.7V$ , the collector-emitter voltage  $V_2$  of the transistor Q2 is

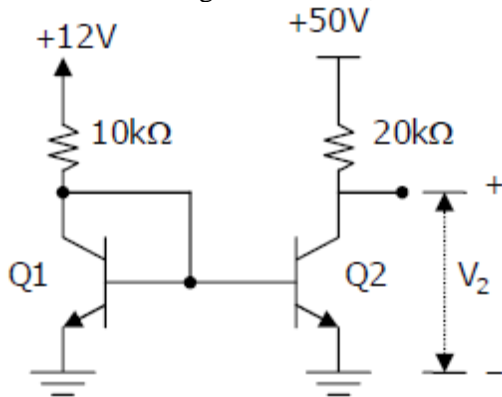

- (A) 33.9V
- (B) 27.8V
- (C) 16.2V
- (D) 0.7V

34. The volume of a cylinder is computed from measurements of its height ( $h$ ) and diameter ( $d$ ). A set of several measurements of height has an average value of  $0.2m$  and a standard deviation of  $1\%$ . The average value obtained for the diameter is  $0.1m$  and the standard deviation is  $1\%$ . Assuming the errors in the measurements of height and diameter are uncorrelated, the standard deviation of the computed volume is

- (A) 1.00%
- (B) 1.73%
- (C) 2.23%
- (D) 2.41%

35. A thermocouple based temperature measurement system is shown in the adjoining figure. Relevant thermocouple emf data (in mV) is given below. The cold junction is kept at  $0^\circ C$ . The temperature is  $30^\circ C$  in the other parts of the system. The emf  $V_0$  is measured to be  $26.74mV$ . The temperature of the hot liquid is

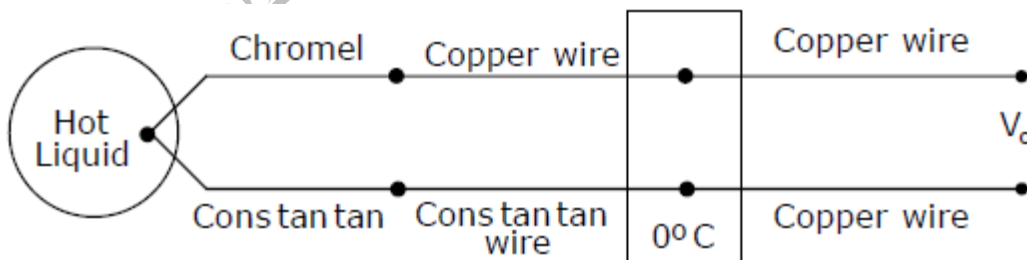

| Temperature  | Emf of Chromel-Constantan | Emf of Copper-Constantan |
|--------------|---------------------------|--------------------------|
| $10^\circ C$ | 0.591                     | 0.391                    |
| $20^\circ C$ | 1.192                     | 0.789                    |
| $30^\circ C$ | 1.801                     | 1.196                    |

|        |        |        |
|--------|--------|--------|
| 370 °C | 26.549 | 19.027 |
| 380 °C | 27.345 | 19.638 |

- (A) 370.0 °C (C) 376.6 °C  
 (B) 372.4 °C (D) 380.0 °C

36. A differential pressure transmitter is used to measure the flow rate in a pipe. Due to aging, the sensitivity of the pressure transmitter is reduced by 5%. All other aspects of the flow meter remaining constant, change in the sensitivity of the flow measurement is

- (A) 10.0% (C) 2.5%  
 (B) 5.0% (D) 2.2%

37. The asymptotic Bode magnitude plot of a lead network with its pole and zero on the left half of the s-plane is shown in the adjoining figure. The frequency at which the phase angle of the network is maximum (in rad/s) is

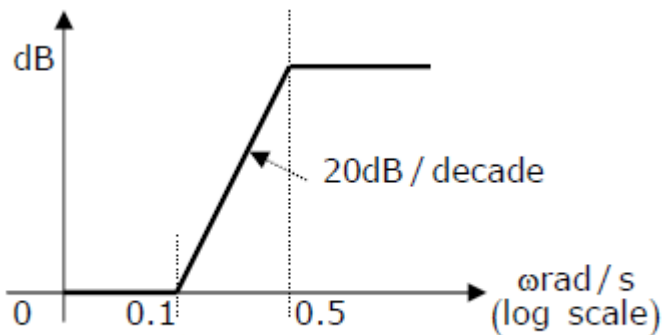

- (A)  $\frac{3}{\sqrt{10}}$  (C)  $\frac{1}{20}$   
 (B)  $\frac{1}{\sqrt{20}}$  (D)  $\frac{1}{30}$

38. In an analog single channel cathode ray oscilloscope (CRO), the x and y sensitivities are set as 1ms/div. and 1V/div. respectively. The y-input is connected to a voltage signal  $4 \cos(200\pi - 45^\circ)$  V. The trigger source is internal, level chosen is zero and the slope is positive. The display seen on the CRO screen is



41. A 4-bit successive approximation type ADC has a full scale value of 15V. The sequence of the states, the SAR will traverse, for the conversion of an input of 8.15V is

- (A) Start conversion → 1 0 0 0 → 1 1 0 0 → 1 0 1 0 → 1 0 0 1 → 1 0 0 0 → End conversion
- (B) Start conversion → 1 0 0 0 → 0 1 0 0 → 0 0 1 0 → 0 0 0 1 → 0 0 0 0 → End conversion
- (C) Start conversion → 1 0 0 0 → 0 1 0 0 → 0 1 1 0 → 0 1 1 1 → 1 0 0 0 → End conversion
- (D) Start conversion → 1 0 0 0 → 1 1 0 0 → 1 1 1 0 → 1 1 1 1 → 1 1 1 1 → End conversion

42. The logic gate circuit shown in the figure realizes the function

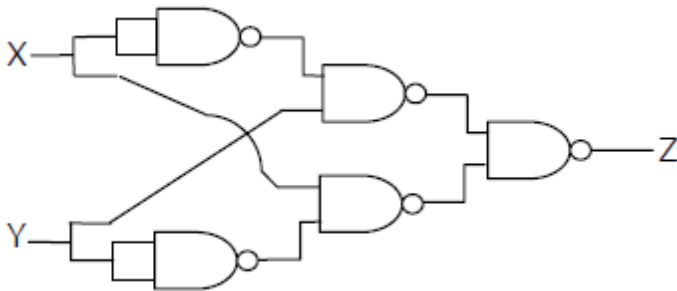

- (A) XOR
  - (B) XNOR
  - (C) Half adder
  - (D) Full adder
43. In an 8085 processor, the main program calls the subroutine SUB1 given below. When the program returns to the main program after executing SUB1, the value in the accumulator is

| Address | Opcode Mnemonic |
|---------|-----------------|
| 2000    | 3E 00           |
| 2002    | CD 05 20        |
| 2005    | 3C              |
| 2006    | C9              |

```

SUB1: MVI A,00h
      CALL SUB2
SUB2: INR A
      RET
    
```

- (A) 00
- (B) 01
- (C) 02
- (D) 03

44. Light coming out of an optical fiber is incident on a plane perpendicular to the fiber axis and 50mm away from the end of the fiber. The light coming out creates a circular spot that can at most be of 20mm diameter. Neglecting the diameter of the fiber, the numerical aperture of the fiber is, approximately
- (A) 0.14 (C) 0.34  
(B) 0.20 (D) 0.40
45. A solution "P" is put in a spectrophotometer cuvette of optical path length 1cm. The transmittance is found to be 10%. Another solution "Q" has a transmittance of 40% under the same circumstances. If equal volumes of P and Q are mixed together, the transmittance of the resulting solution (assuming the constituents of P and Q do not react with each other) is, approximately,
- (A) 15% (C) 25%  
(B) 20% (D) 30%
46. 4-point DFT of a real discrete-time signal  $x[n]$  of length 4 is given by  $X[k]$ ,  $n=0,1,2,3$ , and  $k=0,1,2,3$ . It is given that  $X[0]=5, X[1]=1+j, X[2]=0.5$ .  $X[3]$  and  $X[0]$  respectively are
- (A)  $1-j, 1.875$  (C)  $1+j, 1.875$   
(B)  $1-j, 1.500$  (D)  $0.1-j0.1, 1.500$
47. An active filter is shown in the adjoining figure. The dc gain and the 3dB cut-off frequency of the filter respectively, are, nearly

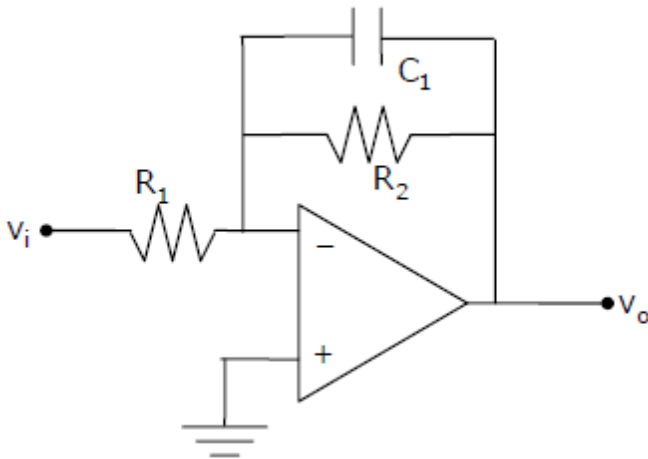

$R_1 = 15.9 \text{ k}\Omega$ ,  $R_2 = 159 \text{ k}\Omega$ ,  $C_1 = 1.0 \text{ nF}$

- (A) 40dB, 3.14 kHz (C) 20dB, 6.28 kHz  
(B) 40dB, 1.00 kHz (D) 20dB, 1.00 kHz

**Common Data for Questions: 48 & 49**

A differential amplifier is constructed using an ideal opamp as shown in the adjoining figure. The values of  $R_1$  and  $R_2$  are  $47\text{k}\Omega$  and  $470\text{k}\Omega$  respectively.

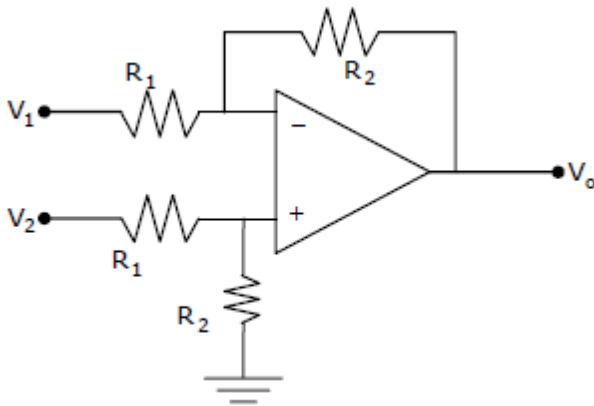

48. The input impedances seen looking into the terminals  $V_1$  and  $V_2$ , with respect to ground, respectively are
- (A)  $47\text{k}\Omega$  and  $43\text{k}\Omega$  (C)  $47\text{k}\Omega$  and  $517\text{k}\Omega$   
 (B)  $47\text{k}\Omega$  and  $47\text{k}\Omega$  (D)  $517\text{k}\Omega$  and  $517\text{k}\Omega$
49.  $V_1$  and  $V_2$  are connected to voltage sources having an open circuit output of  $+1\text{V}$  each and internal resistances of  $13\text{k}\Omega$  and  $3\text{k}\Omega$  respectively. The output voltage  $V_0$  is
- (A)  $0\text{V}$  (C)  $1.5\text{V}$   
 (B)  $0.15\text{V}$  (D)  $10\text{V}$

**Common Data for Questions: 50 & 51**

A PMMC type ammeter has full scale current of  $100\ \mu\text{A}$  and a coil resistance of  $100\ \Omega$

50. The resistance required to convert the  $100\ \mu\text{A}$  ammeter into  $1\text{A}$  full scale dc ammeter is
- (A)  $10\text{m}\Omega$  in series with the meter (C)  $1\text{m}\Omega$  in series with the meter  
 (B)  $10\text{m}\Omega$  in parallel with the meter (D)  $1\text{m}\Omega$  in parallel with the meter
51. The above PMMC meter is connected in the circuit shown in the adjoining figure. The opamp is ideal. The voltage  $v_i(t) = 1.0\sin 314t\ \text{V}$ . Assuming the source impedance of  $v_i(t)$  to be zero, the ammeter will indicate a current of

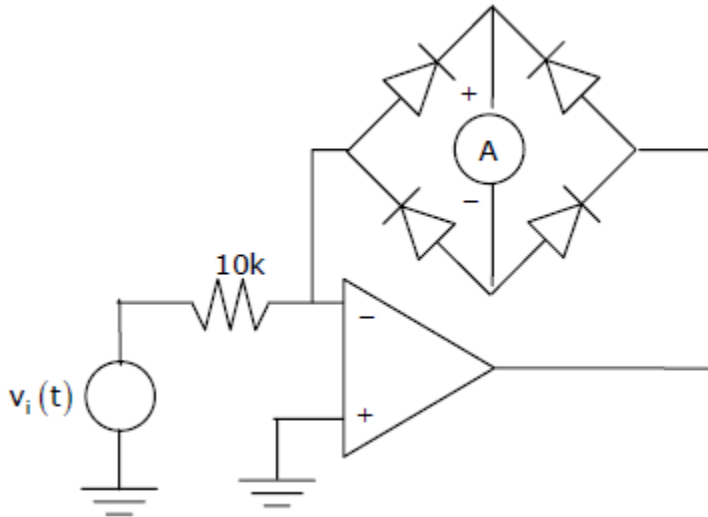

- (A)  $100\mu\text{A}$  (C)  $63.7\mu\text{A}$   
 (B)  $70.7\mu\text{A}$  (D)  $31.8\mu\text{A}$

### Linked Answer Questions:

#### Statement for Linked Answer Questions: 52 & 53

A coil having an inductance ( $L$ ) of  $10\text{mH}$  and resistance  $R$  is connected in series with an ideal  $100\mu\text{F}$  capacitor ( $C$ ). When excited by a voltage source of value  $10\sqrt{2}$  ( $1000t$ )V, the series RLC circuit draws  $20\text{W}$  of power.

52. The value of the coil resistance  $R$  is  
 (A)  $1\Omega$  (C)  $4\Omega$   
 (B)  $2\Omega$  (D)  $5\Omega$
53. The  $Q$  factor of the coil at an angular frequency of  $1000\text{rad/s}$  is  
 (A) 1 (C) 4  
 (B) 2 (D) 5

#### Statement for Linked Answer Questions: 54 & 55

Consider a temperature measurement scheme shown in the adjoining figure. It uses an RTD whose resistance at  $0^\circ\text{C}$  is  $100\Omega$  and temperature coefficient of resistance ( $\alpha$ ) is  $0.00392/^\circ\text{C}$ .

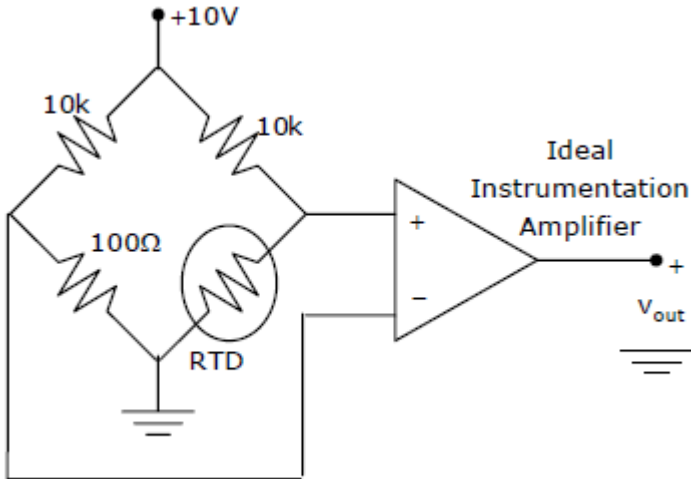

54. The differential gain of the instrumentation amplifier to achieve a voltage sensitivity of  $10\text{mV}/^\circ\text{C}$  at  $0^\circ\text{C}$  should be approximately
- (A) 13.41  
 (B) 26.02  
 (C) 57.53  
 (D) 90.14
55. The RTD is placed in a hot water bath of temperature  $100^\circ\text{C}$ . Based on the gain calculated in Q.54, the error in the measured value of the temperature due to bridge nonlinearity is
- (A)  $-0.1^\circ\text{C}$   
 (B)  $-0.4^\circ\text{C}$   
 (C)  $-0.9^\circ\text{C}$   
 (D)  $+1.2^\circ\text{C}$

### General Aptitude (GA) Question

#### Q. 56 – Q. 60 Carry One Mark Each.

56. 25 persons are in a room. 15 of them play hockey, 17 of them play football and 10 of them play both hockey and football. Then the number of persons playing neither hockey nor football is:
- (A) 2  
 (B) 17  
 (C) 13  
 (D) 3
57. Choose the most appropriate word from the options given below to complete the following sentence:  
 If we manage to \_\_\_\_\_ our natural resources, we would leave a better planet for our children.
- (A) uphold  
 (B) restrain  
 (C) cherish  
 (D) conserve

58. The question below consists of a pair of related words followed by four pairs of words. Select the pair that best expresses the relation in the original pair.

**Unemployed : Worker**

- (A) fallow : land
- (B) unaware : sleeper
- (C) wit : jester
- (D) renovated : house

59. Which of the following options is the closest in meaning to the word below:

**Circuitous**

- (A) cyclic
- (B) indirect
- (C) confusing
- (D) crooked

60. Choose the most appropriate word from the options given below to complete the following sentence:

**His rather casual remarks on politics \_\_\_\_\_ his lack of seriousness about the subject.**

- (A) masked
- (B) belied
- (C) betrayed
- (D) suppressed

**Q. 61 – Q. 65 Carry Two Marks Each.**

61. Hari (H), Gita (G), Irfan (I) and Saira (S) are siblings (i.e. brothers and sisters). All were born on 1<sup>st</sup> January. The age difference between any two successive siblings (that is born one after another) is less than 3 years. Given the following facts:

- i. Hari's age + Gita's age > Irfan's age + Saira's age
- ii. The age difference between Gita and Saira is 1 year. However, Gita is not the oldest and Saira is not the youngest.
- iii. There are no twins.

In what order were they born (oldest first)?

- (A) HSI G
- (B) SGHI
- (C) IGSH
- (D) IHSG

62. 5 skilled workers can build a wall in 20 days; 8 semi – skilled workers can build a wall in 25 days; 10 unskilled workers can build a wall in 30 days. If team has 2 skilled, 6 semi-skilled and 5 unskilled workers, how long will it take to build the wall?

- (A) 20 days (C) 16 days  
(B) 18 days (D) 15 days

63. Modern warfare has changed from large scale clashes of armies to suppression of civilian populations. Chemical agents that do their work silently appear to be suited to such warfare; and regretfully, there exist people in military establishments who think that chemical agents are useful tools for their cause.

Which of the following statements best sums up the meaning of the above passage;

- (A) Modern warfare has resulted in civil strife.  
(B) Chemical agents are useful in modern warfare.  
(C) Use of chemical agents in warfare would be undesirable.  
(D) People in military establishments like to use chemical agents in war.

64. Given digits 2, 2, 3, 3,3, 4, 4, 4, 4 how many distinct 4 digit numbers greater than 3000 can be formed?

- (A) 50 (C) 52  
(B) 51 (D) 54

65. If  $137 + 276 = 435$  how must is  $731 + 672$ ?

- (A) 534 (C) 1623  
(B) 1403 (D) 1513

